

**Infinity**<sup>®</sup>  
**CAR AUDIO**

*Kappa*

54a 4-Ch Power Amplifier

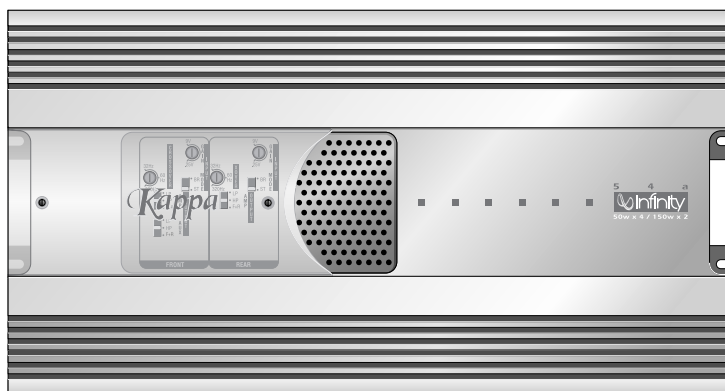

**Owner's Manual  
Installation Guide**

# KAPPA 54A POWER AMPLIFIER

The Kappa 54a is a member of Infinity's new Kappa series of mobile power amplifiers. Housed within the sleek, extruded aluminum frame, you'll find the latest advances in circuit topology, along with user conveniences like a wide-range input sensitivity control, auxiliary outputs, and a built-in electronic crossover. With features like these and more, you can quickly try out a variety of system ideas, and because the Kappa 54a belongs to a related product family, you're assured future expansion will look as good as it sounds.

## KAPPA 54A AMPLIFIER FEATURES...

The Kappa 54a is a 4-channel power amplifier that offers stereo, bridged-mono, or tri-mode operation, and is rated at 50 watts (rms) per channel into a 4-ohm load. In a bridged-mono configurations, front and rear amplifiers can deliver up to 150 watts (rms) for the same load. The 54a also features:

- 2-ohm operation, rated at 75 watts (rms) per channel
- Bridge/stereo switches for fast system setup
- Built-in 12 dB-per-octave electronic crossovers, variable from 32 to 320 Hz
- Individually selectable high- and low-pass filters for all outputs (with through-pass on amplifier outputs and front/rear sum on auxiliary outputs)
- Amplifier input sensitivity controls to match a wide range of input signal levels from 250 mV to 9 V
- Five protection levels guard against over-voltage, under-voltage, over-power, over-temperature, and over-current situations
- 2-color LED array indicates green when power is on and orange when protection is activated
- Industrial-grade, gold-plated, "pre-wire and plug-in" connectors for an easy-to-install high-quality interface
- Transparent control cover to deter tampering yet provide a clear view of installation settings
- Built-in automotive type fuses to protect the amplifier
- Unibloc™ chassis provides improved heat-sink capacity and exceptional RFI shielding characteristics

## ABOUT THE WARRANTY...

You've selected a premium product that offers superior performance and advanced materials, resulting from over 25 years of car audio design. This Infinity product is made with our ongoing dedication to creating the best consumer audio products possible. As a result, you can expect your new Kappa Power Amplifier to provide you with many years of listening enjoyment.

All Infinity Automotive Products carry a limited parts and labor warranty (see the enclosed warranty card), so retain the bill of sale to protect your purchase and to aid us with any service-related questions you may have.

## ABOUT THIS MANUAL...

To attain maximum amplifier performance, we encourage you to read the remaining pages before installing and operating your new Infinity Kappa Power Amplifier. Especially review the *Applications* section (on the next page) for ideas on designing a system. Also, save these instructions for future reference.

**IMPORTANT: Installation of automotive stereo components can require extensive experience in performing a variety of electrical, and mechanical procedures. Although these instructions explain how to install a Kappa Power Amplifier in a general sense, they do not show the exact installation methods for your particular vehicle. If you do not have the experience, do not attempt the installation yourself; instead ask your Authorized Infinity Car Audio Dealer about professional installation options.**



## TABLE OF CONTENTS...

Applications .....	3
System Expansion .....	4
Precautions And Notes .....	5
Installation .....	6
Troubleshooting.....	8

# APPLICATIONS

For your convenience, we've included several application diagrams to help you plan your own system installation. Figures 1 through 3 show how to configure the Kappa 54a for stereo, bridged-mono, and tri-mode operation.

Figure 1. This wiring diagram shows a Kappa 54a amplifier driving front and rear pairs of full-range speakers.

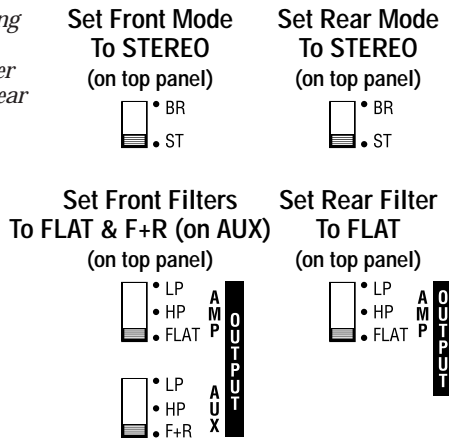

For system expansion ideas, see the next page.

NOTE: For simplicity, Figures 1 through 3 do not show power, remote, and input connections.

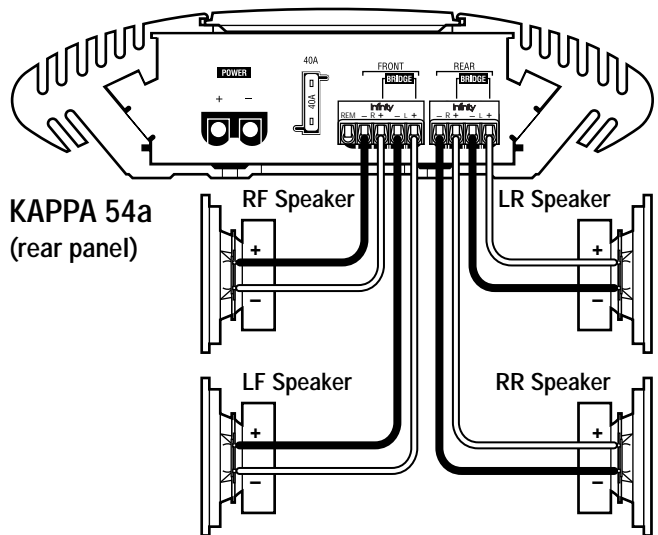

Figure 2. This wiring diagram shows a Kappa 54a amplifier driving a front pair of tweeter/midrange systems and a rear pair of full-range speakers.

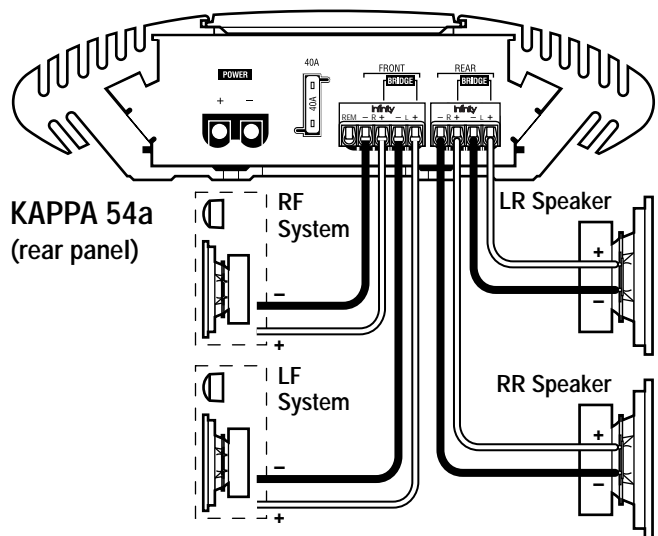
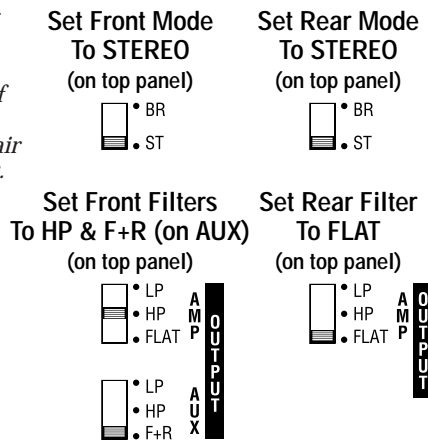
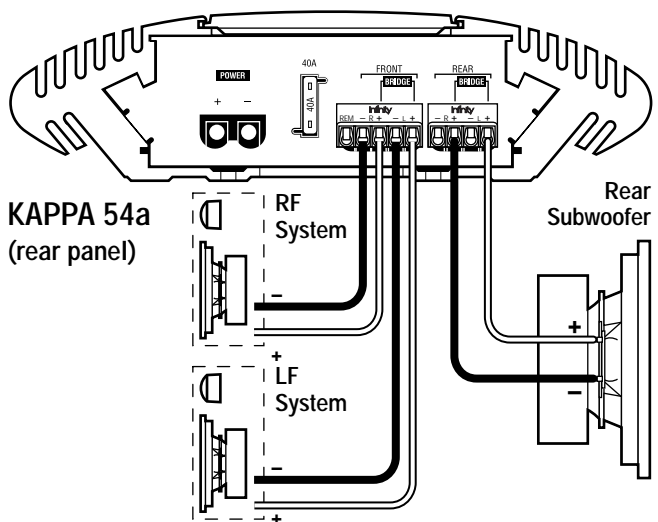
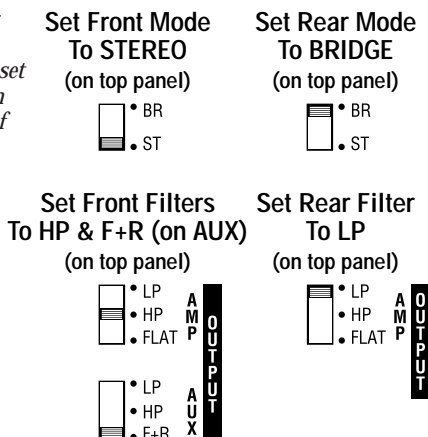

Figure 3. This wiring diagram shows a Kappa 54a amplifier set for tri-mode operation to drive a front pair of tweeter/midrange systems and a single rear subwoofer.



# SYSTEM EXPANSION

Figure 4. In this example system, a Kappa 54a drives front and rear pairs of 5 1/4" speakers. The 54a's stereo front and rear outputs are summed to feed a bridged-mono Kappa 202a that drives a single 12" subwoofer.

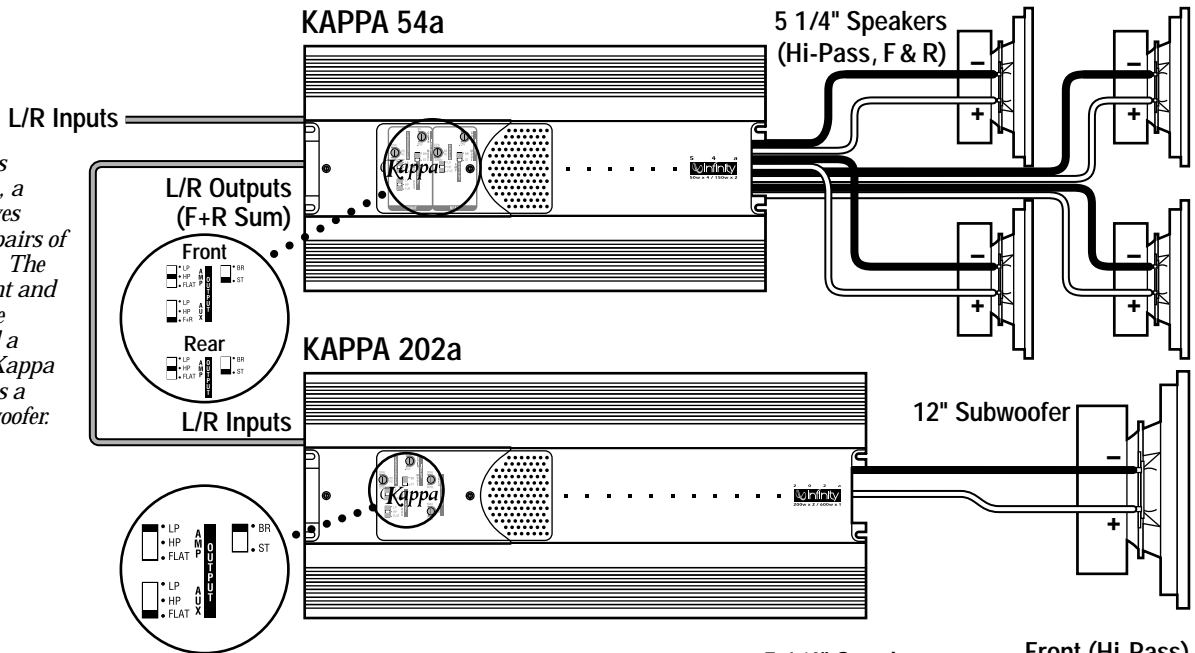
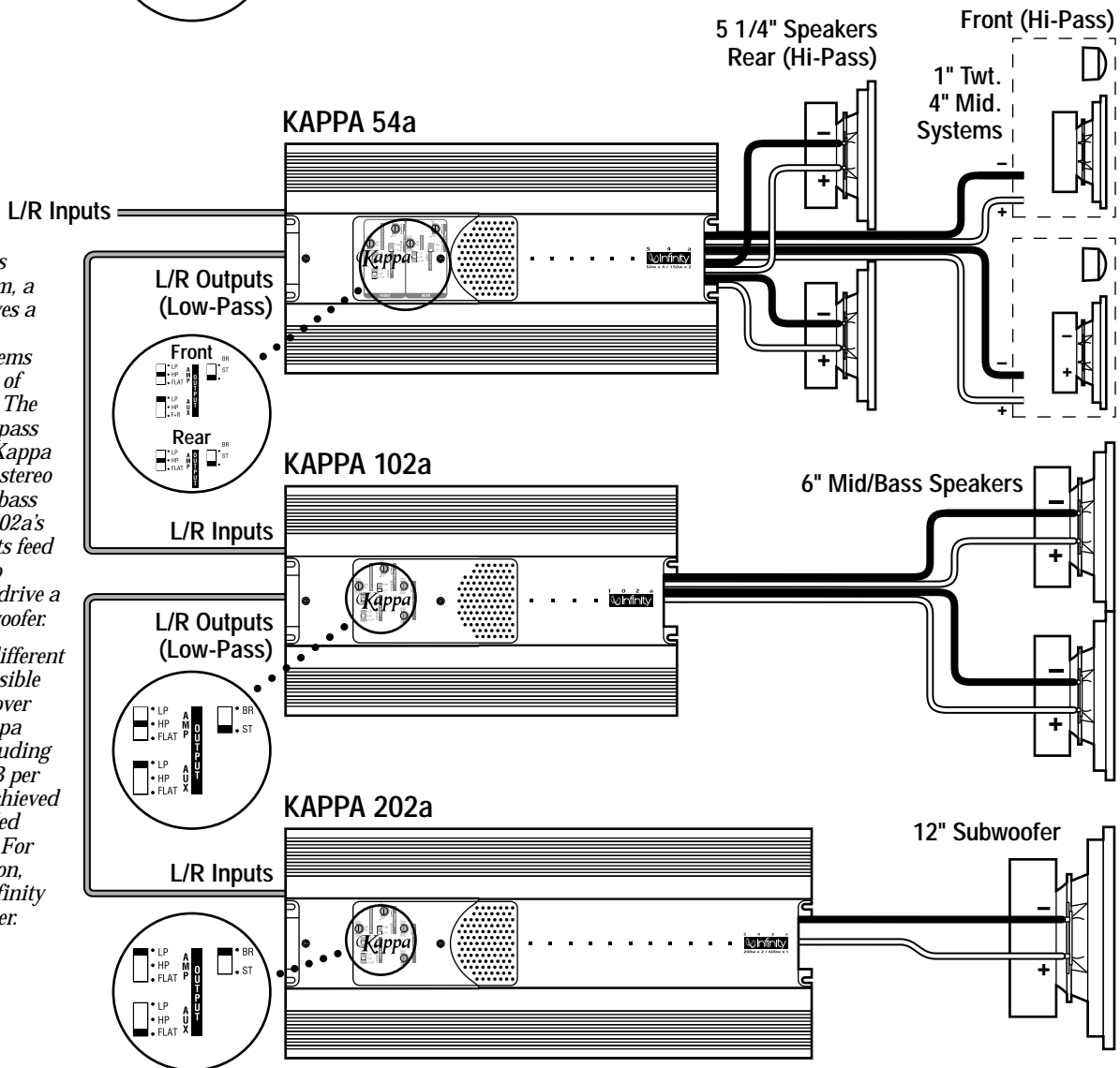

Figure 5. In this expanded system, a Kappa 54a drives a front pair of component systems and a rear pair of 5 1/4" speakers. The 54a's front low-pass outputs feed a Kappa 102a to drive a stereo pair of 6" mid/bass speakers. The 102a's low-pass outputs feed a bridged-mono Kappa 202a to drive a single 12" subwoofer.

NOTE: Many different systems are possible using the crossover settings on Kappa amplifiers, including ones with 24 dB per octave slopes achieved through cascaded configurations. For more information, consult your Infinity Car Audio dealer.



## PRECAUTIONS AND NOTES

- The Kappa 54a has five levels of circuit protection that monitor the amplifier and will shut it down if the electrical system voltage drops below 10 Vdc or exceeds 15.5 Vdc, temperatures are above 194° F (90° C), short circuits occur, or current draw exceeds product specifications. For best performance, check the intended mounting site to make sure the operating environment does not create conditions that will trigger circuit protection.
- Prior to installation, turn off all audio systems and other electrical devices. Also disconnect the (-) negative lead from the vehicle's battery.
- At the installation site, locate and make a note of all fuel lines, hydraulic brake lines, and electrical wiring. Use extreme caution when cutting or drilling in and around these areas.
- Use the amplifier as a mounting template to mark locations for the mounting holes.
- Check clearances on both sides of a planned mounting surface before drilling any holes or installing any screws. Remember that mounting screws can extend up to an inch behind the surface.
- Always wear protective eyewear when using tools.
- The Kappa 54a uses gold-plated, industrial-grade Weco® plug-in connectors for power and speaker wiring. Because of precision tolerances, do not insert the connectors into the amplifier without pre-wiring them first. Once the wires are fastened in each shell, they provide additional gripping area for easy connector removal.
- When routing cables, keep input signal cables away from power cables and output speaker wires, as shown in Figure 6 (below).
- When making connections, make sure that each connection is clean and properly secured. Observe the polarity markings on the rear panel. Refer to the application drawings (Figures 1 through 3 on page 3) to set up the amplifier for operation in stereo, bridged-mono, bi-amp, or tri-mode configurations.
- If the amplifier's fuse needs replacement, use only the same rating and type as a replacement. Do not substitute another kind.

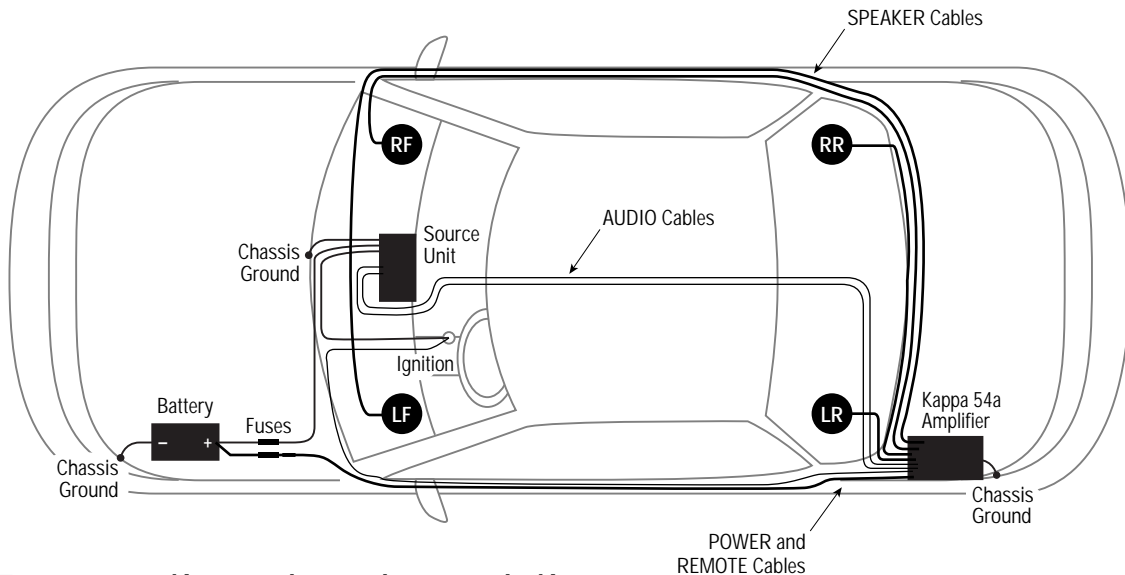

Figure 6. To minimize possible noise pickup, use this suggested cable routing scheme to plan your amplifier installation.

## INSTALLATION

The Kappa 54a is easy to install. For optimum performance, we recommend using high-quality, twisted-pair shielded RCA audio cables and 14-gauge or larger speaker wire. Also, you'll need a minimum of 12-gauge stranded copper wire (e.g., red and black jackets) for the power connections. Use 18-gauge (e.g., blue jacket) wire for remote turn-on.

Depending on your total system plan, allow for adequate time and the possibility of overnight storage of your vehicle, since it may take more than one day to complete the installation.

### PARTS LIST...

Examine and verify that the package includes the following items:

- (1) Kappa 54a Power Amplifier
- (1) Spare ATC fast-blow fuse (40 A)
- (1) Control cover with (2) machine screws
- (1) Weco 5-pin audio connector
- (1) Weco 2-pin power connector
- (4) #8 mounting screws

### MOUNTING THE AMPLIFIER...

The Kappa 54a can be mounted in virtually any location **inside** the vehicle. However, make sure to keep the amplifier away from heater vents or ducts.

1. At the chosen site, use the amplifier as a mounting template and mark locations of the four mounting holes.
2. Drill a small pilot hole at each marked location.
3. Mount the amplifier and securely tighten the mounting screws.

### WIRING THE AMPLIFIER...

Refer to Figure 7 (below) for details of the Kappa 54a's front and rear panel connections.

1. For power, remote, and speaker wires, strip 1/4" off one end of each jacket to reveal bare wire for insertion into the Weco connectors.
2. Using the Weco 2-pin power connector, connect a black wire from the nearest bare-metal chassis component to the (-) terminal. Then, connect a red wire from the vehicle's +12-volt battery terminal to the (+) terminal.

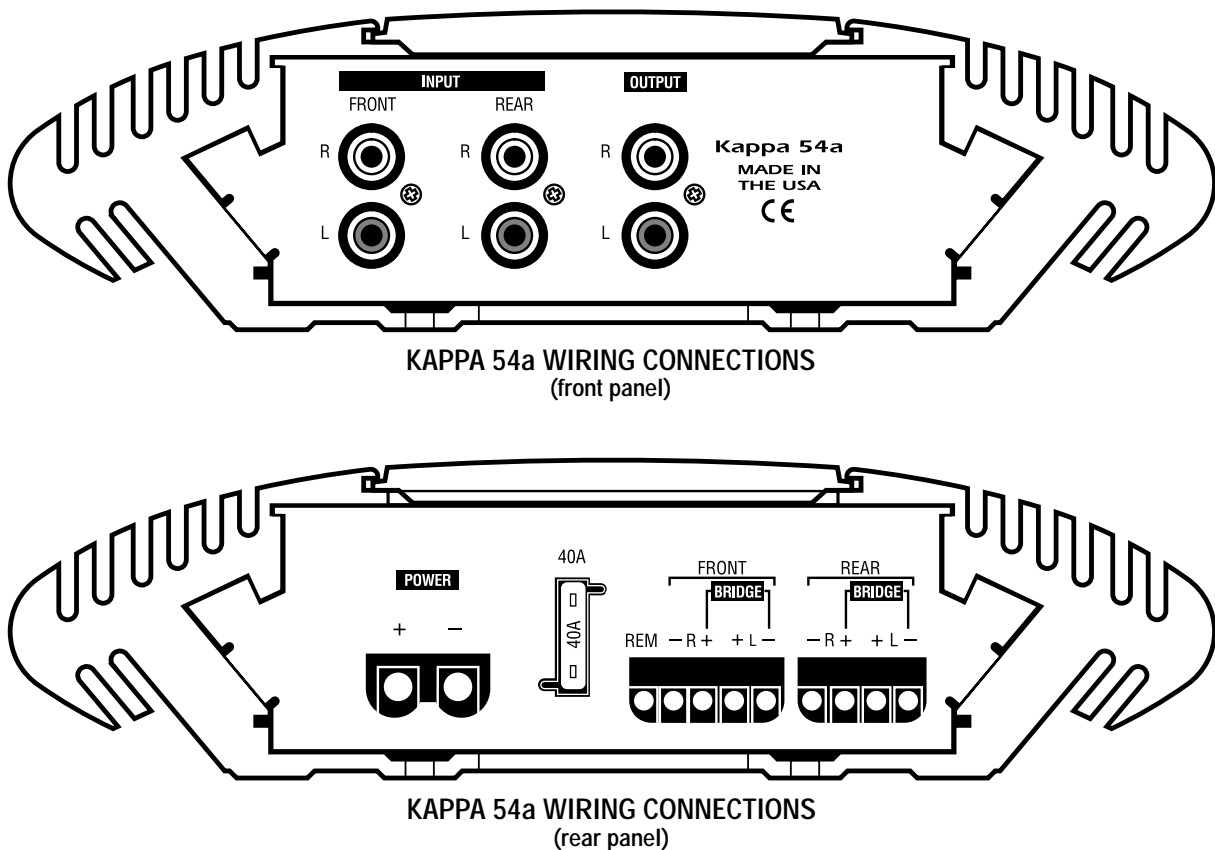

Figure 7. Wiring connections for the Kappa 54a amplifier.

## INSTALLATION (continued)

3. Make sure the wires are firmly seated in the Weco 2-pin connector and that each screw is completely tightened. Insert the wired connector into the POWER socket on the amplifier. Press it in until it stops.
4. Using the Weco 5-pin connector, connect a blue wire from the source unit's remote connection to the REM terminal. Depending on polarity requirements (e.g., bridged-mono or tri-mode configurations – see Figures 1 through 3 on page 3), connect speaker wires from the speakers to the L and R (+ and -) terminals, as required by your system plan.
5. Make sure the wires are firmly seated in the Weco 5-pin connector and that each screw is completely tightened. Insert the wired Weco 5-pin connector into the 5-pin socket on the amplifier. Press it in until it stops.
6. Connect RCA cables from a source unit to the L and R INPUT jacks.

### SETTING THE CROSSOVER...

**IMPORTANT: If you plan to use the Kappa 54a to drive full-range speakers, set both AMP and AUX filters to FLAT (refer to Figure 1 on page 3 and Figure 8 below) and skip to the next section, "Setting Input Sensitivity".**

1. Set the front and rear CROSSOVER controls to the frequency recommended by the speaker manufacturer (refer to Figure 8). If the value is unknown, set the control midway.

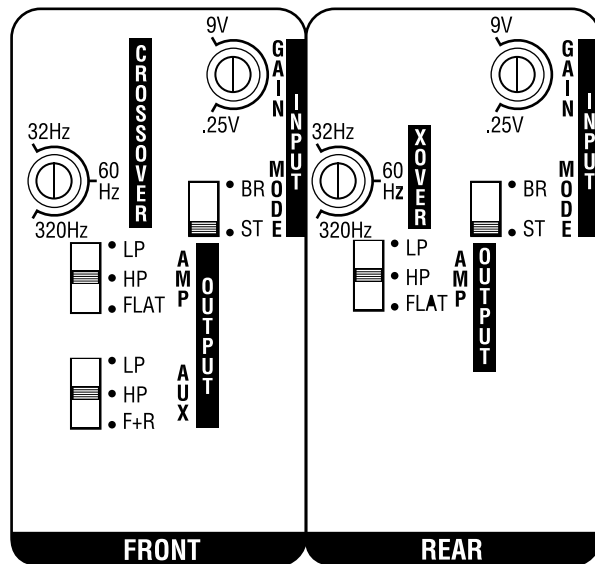

Figure 8. Kappa 54a front and rear controls for crossover, input, and output.

2. Depending on your system plan, set the AMP and AUX switches to LP (low-pass), HP (high-pass), or FLAT (refer to Figure 8).

### SETTING INPUT SENSITIVITY...

Initially, turn the front and rear input sensitivity GAIN controls to their minimum (counter-clockwise) positions (refer to Figure 8).

1. Reconnect the (-) negative lead to your vehicle's battery. Apply power to the audio system and play a favorite music track from CD or tape.

*NOTE: After the source unit is on, green LEDs (on the top panel) will illuminate, indicating the amplifier is on. If not, check the wiring, especially the remote connection from the source unit. Also refer to "Troubleshooting" on the next page.*

2. On the source unit, increase the volume control to maximum position. Slowly increase the Front and Rear GAIN controls (clockwise) towards three o'clock and, at the same time, listen to the quality of the reproduced sound. At some point, you'll hear distortion on the music peaks. Stop the adjustment and turn it back slightly.

### INSTALLING THE CONTROL COVER...

After wiring and testing the Kappa 54a amplifier, install the control cover using the enclosed machine screws to deter tampering and help seal out dust.

*NOTE: Do not over-tighten the machine screws. Doing so may crack the cover.*

## TROUBLESHOOTING

Use the following guide to identify symptoms and solve problems. Make sure the vehicle's electrical system is working properly and power is reaching the Kappa 54a (i.e., green LEDs on the top panel are on).

SYMPTOM	LIKELY CAUSE	SOLUTION
No audio	Low/No Remote Turn-On Voltage	Check connections; test turn-on voltage
	Speakers are not connected or are blown	Check wiring; use VOM/DVM to measure speaker coil impedance
Distorted audio	Input sensitivity is not set properly	See <i>Setting Input Sensitivity</i> on previous page
Audio lacks "punch"	Speakers are wired with wrong polarity	Check polarity of connections; refer to <i>Applications</i> (page 3)

SYMPTOM	LIKELY CAUSE	SOLUTION
Audio cycles off and on; Amber protection LEDs (on top panel) are on	A protection circuit is turning the amplifier off and on	Verify the following—electrical system is between 10 ~ 15.5 Vdc; temperature is not over 194°F (90°C); no short circuits; speaker loads are not less than 1 ohm (2 ohms in mono)
Audio cycles off and on; Amber protection LEDs (on top panel) are on	GAIN is set too high	Set Input Sensitivity correctly (see previous page)
Fuse blows	Incorrect wiring or short circuit	Check connections; refer to <i>Applications</i> (see page 3)

## SPECIFICATIONS

### KAPPA 54A...

Power Output, 4 ohms:	4 x 50 watts
Power Output, 2 ohms:	4 x 75 watts
Power Output, Bridged 4 ohms:	2 x 150 watts
Frequency Response:	20 Hz ~ 20 kHz
Input Sensitivity:	250 mV ~ 9 V
THD + Noise (4 ohms):	0.05 %
Signal-to-Noise:	> 95 dB
Maximum Current Draw:	40 A
Dimensions (w x h x l):	16 x 2 <sup>3/16</sup> x 8 <sup>1/2</sup> in. 406.4 x 55.6 x 215.9 mm



©1997, Infinity Systems, Inc., 20630 Nordhoff Street, Chatsworth, CA 91311, USA

VOICE (818) 407-0228 • FAX (818) 709-9486

www.infinitysystems.com

*Infinity constantly strives to update and improve existing products, as well as create new ones; therefore, the specifications and construction details in this and related Infinity publications are subject to change without notice. Unibloc is a trademark of Infinity Systems, Inc.*